

⚡ Specifications

Nominal Voltage(V)

12V

Nominal Capacity

10 hour rate	(15.5A to 10.80V)	155Ah
5 hour rate	(26.35A to 10.20V)	131.75Ah
1 hour rate	(93A to 9.60V)	93Ah

Weight

Approx. 48.2kg(106Lbs.)

Internal Resistance (at 1KHz)

Approx. 3.4 mΩ

Maximum Discharge Current for

5 seconds: 1550A

Charging Methods at 25°C(77°F)

Cycle use:	
Charging Voltage	14.4 to 15.0V
Coefficient -5.0mV/°C/cell	
Maximum Charging Current :	46.5A
Standby use:	
Float Charging Voltage	13.5 to 13.8V
Coefficient -3.0mV/°C/cell	

Operating Temperature Range

Charge	-15°C(5°F)	to	40°C(104°F)
Discharge	-15°C(5°F)	to	50°C(122°F)
Storage	-15°C(5°F)	to	40°C(104°F)

Charge Retention (shelf life) at 20°C(68°F)

1 month	98%
3 month	94%
6 month	85%

Case Material

ABS UL94 HB
Option: Flammability resistance of (UL94 V-0)

Design Life & Standard

Expected Trickle Design Life: 10-12 years at 20°C according to Eurobat.

Terminal

F18



⚡ Dimensions

Length (L)	483±3 (19.02±0.12)
Width (W)	170±3 (6.69±0.12)
Height (H)	240±3 (9.45±0.12)
Overall Height (HT)	240±3 (9.45±0.12)

Description of torque value of hard ware for the terminals:

Recommended torque value	M8:12 N-m (122kgf-cm)
Maximum allowable torque value	M8:15 N-m (153kgf-cm)

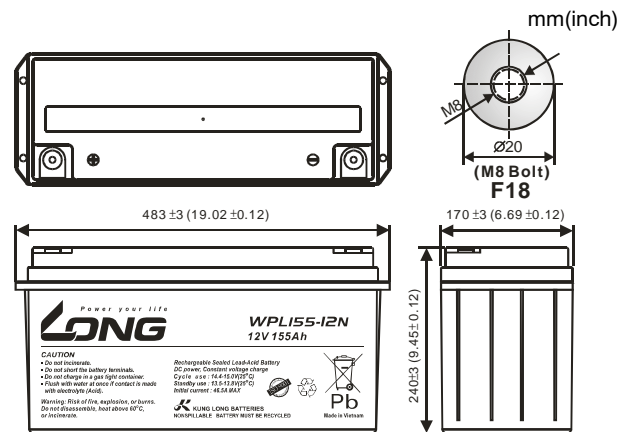

(V) FOR 12V BATTERY Discharge Time VS. Discharge Current (25°C)

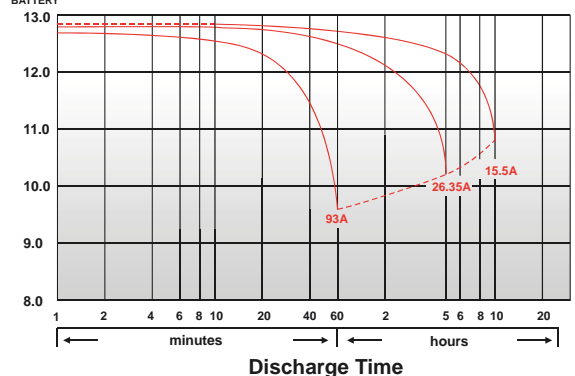

Effect of Temperature on Capacity 25°C(77°F)

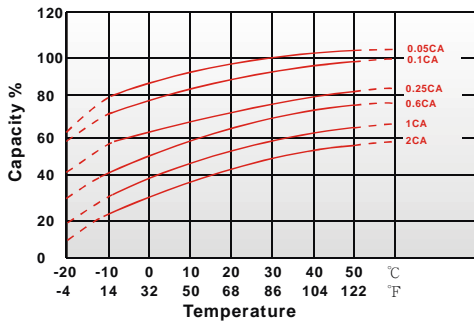

Capacity Retention Characteristic

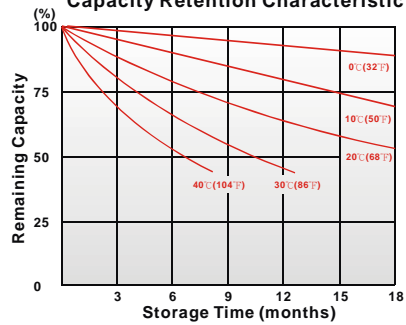

Cycle Service Life

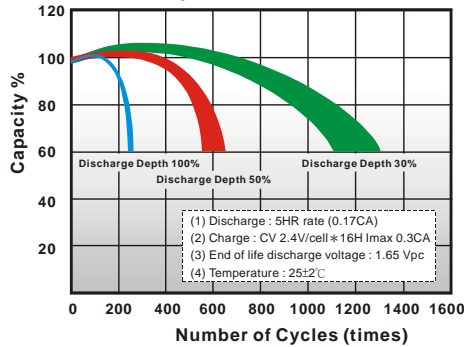

Trickle (or float) Service Life

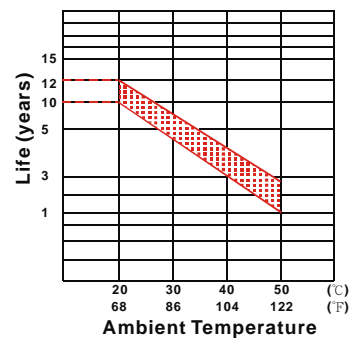

- PERFORMANCE DATA

Discharge Rates in Watts to Various End Voltages at 25°C(77°F)

End Voltage		1.80V	1.75V	1.70V	1.65V	1.60V
Time						
10	min	566	605	643	698	724
15	min	483	505	533	573	616
20	min	406	420	437	459	498
30	min	312	317	324	328	355
45	min	251	254	260	267	276
60	min	199	201	206	212	218
120	min	118	121	123	124	126
180	min	90.0	91.5	92.8	93.5	94.2
300	min	56.8	58.2	59.3	60.3	61.7
480	min	37.2	38.0	38.7	39.3	40.7
600	min	30.7	31.5	31.8	32.3	33.7

- Discharge Rates in Amperes to Various End Voltages at 25°C(77°F)

End Voltage		1.80V	1.75V	1.70V	1.65V	1.60V
Time						
10	min	275	300	326	340	375
15	min	231	250	270	278	300
20	min	194	206	219	223	237
30	min	156	162	167	169	176
45	min	115	119	123	125	128
60	min	94.2	97.2	100	103	106
120	min	55.9	58.2	59.2	60.3	61.3
180	min	42.2	44.3	44.7	45.1	45.4
300	min	27.0	27.5	28.2	28.8	29.4
480	min	18.1	18.3	18.5	18.8	19.0
600	min	15.1	15.2	15.3	15.6	15.7

All data on the spec. sheet is an average value:

The tolerance range : X<6min(+15%~-15%), 6min ≤ X < 10min(+12%~-12%), 10min ≤ X < 60min(+8%~-8%), X ≥ 60min(+5%~-5%)

101218-1G