



BATTERY TEST REPORT

IEC 60896-21 : 2004

IEC 60896-22 : 2004

Report Reference No..... : TQ2212015

Tested by

(printed name and signature) : Le Tan Phong 

Approved by

(printed name and signature) : Adam Chen 

Date of issue..... : 2022-12-14



Testing laboratory..... : Laboratory Le Long Viet Nam Limited Company

Address..... : Cum Cong Nghiep Duc My, Xa Duc Hoa Dong, Huyen Duc Hoa, Tinh Long An, 81999 Viet Nam . Tell:+84-72-3779666

Applicants Name..... : KUNG LONG BATTERIES INDUSTRIAL CO., LTD

Address..... : No., 6 Tzu-Li 3 Road, Nantou City 54067, Nantou Hsien, Taiwan

Test Specification:

Standard..... : IEC 60896-21:2004 and IEC 60896-22:2004

Non-standard test method..... : N/A

Test Report Form No..... : IEC 60896-21:2004 and IEC 60896-22:2004

Test item description..... : Valve Regulated Lead-Acid Battery

Trade Mark..... : 

Model/Type reference..... : WPL155-12N

Series model..... : N/A

Rating(s) : 12V 155Ah

Battery dimension..... : 483mm x 170mm x 240mm (LxWxH)

Possible Test Case Verdicts:

Test case does not apply to the test object.....N/A

Test object does meet the requirement.....P(Pass)

Test object does not meet the requirement.....F(Fail)

Testing Laboratory information:

Laboratory Le Long Viet Nam Limited Company

Cum Cong Nghiep Duc My, Xa Duc Hoa Dong, Huyen Duc Hoa, Tinh Long An, 81999 Viet Nam . Tell: +84-72-3779666





Trade Mark And Dimension:

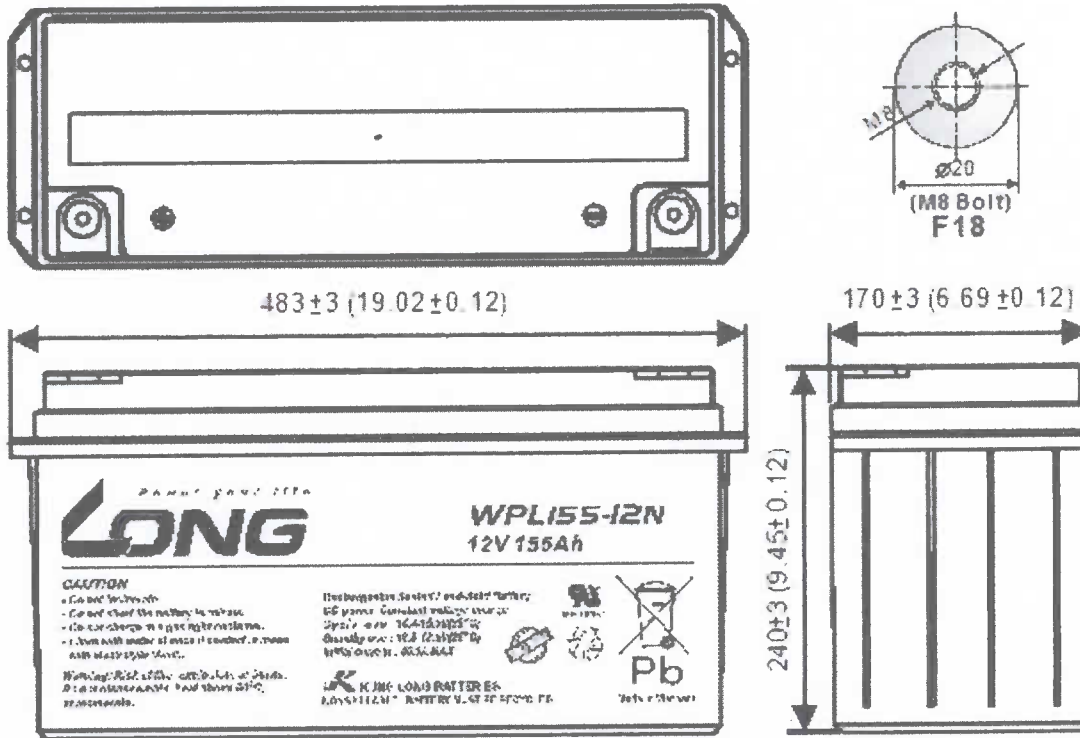

**1. Test Item:**

No	Test Item	Clauses.	Verdict
1	Gas Emission	6.1	P
2	High current tolerance (High current discharge capacity)	6.2	P
3	Short circuit current and DC internal resistance	6.3	P
4	Protection against internal ignition from external spark sources	6.4	P
5	Protection against ground short propensity	6.5	P
6	content and durability of required markings	6.6	P
7	Material Identification	6.7	P
8	Valve operation	6.8	P
9	Flammability rating of materials	6.9	P
10	Intercell connector performance	6.10	P
11	Discharge Capacity	6.11	P
12	Charge retention during storage	6.12	P
13	Float service with daily discharges 25°C,80%	6.13	P
14	Recharge behavior	6.14	P
15	Service life at an operating temperature of 40°C all units to 0.8 C _{rt}	6.15	P
16	Impact of a stress temperature of 60°C,80%	6.16	P
17	Abusive over- discharge	6.17	P
18	Thermal run away sensitivity	6.18	P
19	Low temperature sensitivity	6.19	P
20	Dimensional stability at elevated internal pressure and temperatures	6.20	P
21	Stability against mechanical abuse of units during installation	6.21	P

T
H
ON
NA
I



2. Test Result:

No.	Test Item	Clauses.	Technical Specification	Test data
1	Gas Emission (V=Voltage per cell)	6.1	$U_{f10} \leq 0.05 \text{ml/cell} \cdot \text{h} \cdot \text{Ah} (25^\circ\text{C})$	0.0089
			$2.40 \text{Vpc} \leq 1.70 \text{ml/cell} \cdot \text{h} \cdot \text{Ah} (25^\circ\text{C})$	0.0113
2	High current tolerance (High current discharge capacity)	6.2	Discharge with 3 times of 15min rate current, or with a current equal to the maximum allowable discharge current. there is no melting or continuous power loss. $V_{5\text{min}} > 2.0 \text{Vpc}$	Discharge with 3 times of 15min large current, there is no melting or continuous power loss. $V_{5\text{min}} = 12.95 \text{Voltage}$
3	Short circuit current and DC internal resistance	6.3	I_{sc}	- I_{sc} (Short Circuit Current (A)): 3070A
			Internal Resistance	- 3.40 mΩ (measured by HIOKI 3554 Battery Hitester)
4	Protection against internal ignition from external spark sources	6.4	There is no fast burn or explosive apart from valve	There is no fast burn or explosive apart from valve
5	Protection against ground short propensity	6.5	No earthing short or leakage	No earthing short or leakage
6	content and durability of required markings	6.6	Marks are easy for long-lasting	Marks are easy for long-lasting
7	Material Identification	6.7	ISO symbol is visible, and the symbol is remain after put in chemical reagent place	ISO symbol is visible, and the symbol is remain after put in chemical reagent place
8	Valve operation	6.8	Check the gas outlet before and after high-temp.	Open/close valve pressure (Kpa)is: Bef. high-temp.: 22.4/20.6 After high-temp.: 23.3/21.2
9	Flammability rating of materials	6.9	Indicate sample's value with same thickness of containers and lids	ABS UL94 HB
10	Intercell connector performance	6.10	Indicate highest temp. reached	36.8°C
11.	Discharge Capacity	6.11	$C_{10} \geq 155 \text{Ah}$	103.5% @15.5A
			$C_8 \geq 143 \text{Ah}$	105.8% @17.8A
			$C_5 \geq 116. \text{Ah}$	108.2% @38.8A
			$C_1 \geq 93.0 \text{Ah}$	109.2% @93.0A
			$C_{0.25} \geq 54.3 \text{Ah}$	112.3% @217A



12	Charge retention during storage	6.12	$\geq 70\%$	78.8%
13	Float service with daily discharges 25°C, 80%	6.13	Total Cycle times ≥ 300	359 times
14	Recharge behavior	6.14	$R_{hf24h} \geq 90\%$	98.7%
			$R_{hf168h} \geq 98\%$	100.6%
15	Service life at an operating temperature of 40°C all units to 0.8 C _{rt}	6.15	- Brief duration exposure time $\geq 500d$ - Medium duration exposure time $\geq 750d$ - Long duration exposure time $\geq 1100d$ - Very long duration exposure time $\geq 1700d$	1763d (Very long duration exposure time)
16	Impact of a stress temperature of 60°C, 80%	6.16	- Brief duration exposure time $\geq 105d$ - Medium duration exposure time 175d - Long duration exposure time $\geq 250d$ - Very long duration exposure time $\geq 350d$	375d (Very long duration exposure time)
17	Abusive over-discharge	6.17	Unbalanced series over discharge $C_{aod} > 0.80$	0.88
			Cycle over discharge $C_{aoc} > 0.90$	0.97
18	Thermal run away sensitivity	6.18	Battery temperature change at 2.40VPC, the temperature after 168h	23.2°C
			Battery temperature change at 2.60VPC, the temperature after 168h	29.9°C
19	Low temperature sensitivity	6.19	$C_{als} > 95\%$	96.0%
20	Dimensional stability at elevated internal pressure and temperatures	6.20	percentage deviation over the girth value	$\Delta L = 0.05\%$
21	Stability against mechanical abuse of units during installation	6.21	No fracture or leak of the battery case	No fracture or leak of the battery case



— — — The End of Test Report — — —