

### ⚡ Specifications

#### Nominal Voltage(V)

12V

#### Nominal Power

15 mins rate: 205W/cell to 1.67V/cell

#### Nominal Capacity

20 hour rate	(2.75A to 10.50V)	55Ah
8 hour rate	(5.9A to 10.50V)	47.2Ah
5 hour rate	(9.35A to 10.20V)	46.75Ah

#### Weight

Approx. 17.1kg(37.6Lbs.)

#### Internal Resistance (at 1KHz)

Approx. 6mΩ

#### Maximum Discharge Current for

5 seconds: 660A

#### Short Circuit Current (A) IEC 60896-21-22

1500 A

#### Charging Methods at 25°C(77°F)

Maximum Charging Current :	16.5A
Boost Charging Voltage	14.4 to 15.0V
Boost Charge Time	8-9Hr
Float Charging Voltage	13.5 to 13.8V
Coefficient	-3.0mV/°C/cell

#### Operating Temperature Range

Charge	-15°C (5°F) to 40°C (104°F)
Discharge	-15°C (5°F) to 50°C (122°F)
Storage	-15°C (5°F) to 40°C (104°F)

#### Charge Retention (shelf life) at 20°C(68°F)

1 month	98%
3 month	96%
6 month	94%

#### Case Material

ABS UL94 HB

Option: Flammability resistance of (UL94 V-0)

#### Battery Construction

Component	Positive Plate	Negative plate	Safety valve	Terminal	Separator	Electrolyte
Raw material	Lead dioxide	Lead	Rubber	Lead	AGM	Sulfuric acid



### ⚡ Dimensions

Length (L) 226±<sup>2</sup><sub>1</sub> (8.90±<sup>0.08</sup><sub>0.04</sub>)

Width (W) 135±<sup>2</sup><sub>1</sub> (5.21±<sup>0.08</sup><sub>0.04</sub>)

Height (H) 207±<sup>2</sup><sub>1</sub> (8.15±<sup>0.08</sup><sub>0.04</sub>)

Overall Height (HT) 214±<sup>2</sup><sub>1</sub> (8.43±<sup>0.08</sup><sub>0.04</sub>)

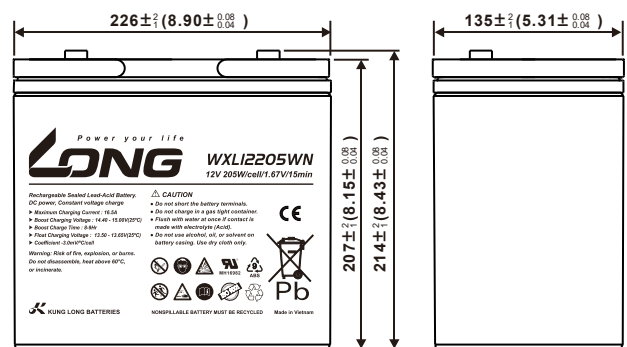
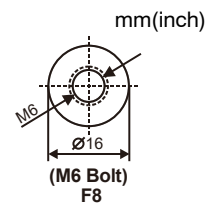
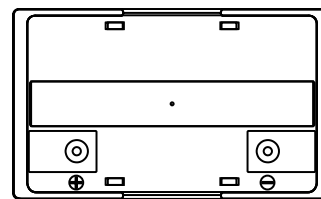

#### Terminal

F8

Recommended torque value M6:7 N-m (71 kgf-cm)

Maximum allowable torque value M6:10N-m (102 kgf-cm)

#### Design Life

EUROBAT(20°C) : 10/12 YEARS LONG LIFE

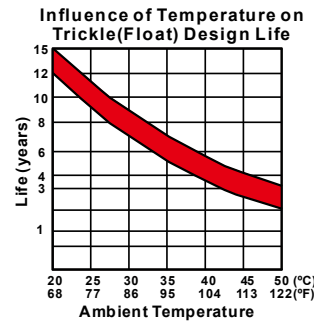
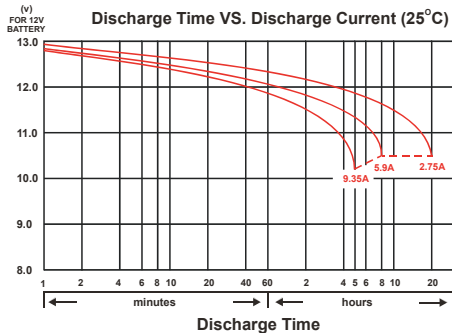
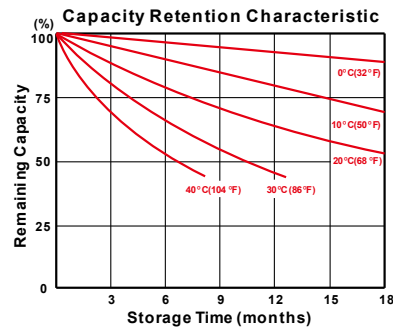
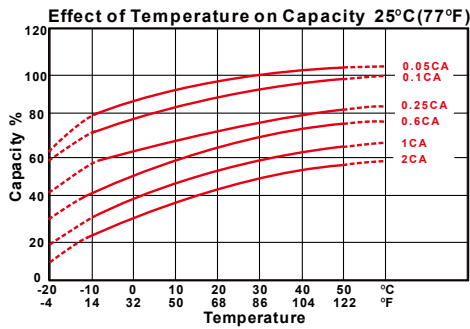

### - PERFORMANCE DATA

#### Discharge Rates in Watts to Various End Voltages at 25°C(77°F)

End Voltage		1.85V	1.80V	1.75V	1.70V	1.67V	1.65V	1.60V
2	min	334	397	429	454	473	490	504
4	min	309	345	374	399	418	435	449
5	min	300	336	365	390	414	431	445
6	min	276	302	324	343	358	373	388
8	min	261	283	301	318	333	348	363
10	min	221	246	266	284	298	305	311
15	min	196	211	222	225	228	231	233
20	min	169	177	182	186	189	192	195
30	min	119	124	128	131	135	138	140
45	min	93.1	96.0	98.0	98.9	99.6	100	101
60	min	65.0	67.4	69.6	71.6	72.1	72.4	72.6
90	min	51.1	53.0	54.5	55.2	55.7	56.1	56.4
120	min	33.3	35.5	37.1	37.7	38.3	38.7	39.1
180	min	26.8	28.7	29.7	30.2	30.6	30.9	31.2
240	min	21.9	22.9	23.8	24.2	24.5	24.7	24.9
300	min	18.4	19.3	20.1	20.3	20.5	20.7	20.9
600	min	10.7	11.1	11.5	11.6	11.8	12.0	12.1
1200	min	5.51	5.75	5.96	6.04	6.09	6.14	6.19

#### - Discharge Rates in Amperes to Various End Voltages at 25°C(77°F)

End Voltage		1.85V	1.80V	1.75V	1.70V	1.67V	1.65V	1.60V
2	min	183	232	259	275	289	301	310
4	min	177	207	226	242	256	269	277
5	min	158	182	196	209	218	226	231
6	min	139	162	173	187	199	209	216
8	min	128	147	159	163	167	171	174
10	min	117	136	147	152	158	162	164
15	min	91.3	101	105	110	114	116	118
20	min	77.6	85.8	89.6	93.6	96.9	98.6	100
30	min	57.9	63.1	65.7	67.4	69.2	70.7	71.6
45	min	46.7	47.6	48.2	48.9	49.5	50.0	50.4
60	min	29.2	32.5	34.3	34.9	35.4	35.8	36.2
90	min	23.1	24.7	25.4	26.0	26.5	26.9	27.0
120	min	16.8	18.1	19.1	19.5	19.9	20.2	20.4
180	min	12.7	13.5	14.0	14.3	14.5	14.7	14.9
240	min	10.8	11.2	11.6	11.8	12.0	12.2	12.4
300	min	8.95	9.34	9.53	9.64	9.80	9.89	10.0
600	min	5.30	5.41	5.51	5.56	5.62	5.68	5.73
1200	min	2.74	2.78	2.81	2.84	2.88	2.91	2.94

All data on the spec. sheet is an average value:

The tolerance range : X<6min(+15%~-15%), 6min≤X<10min(+12%~-12%), 10min≤X<60min(+8%~-8%), X≥60min(+5%~-5%)

211124-1H